

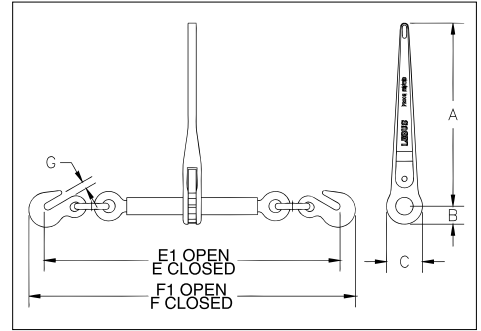

Crosby LEBUS L-140



Load Rated

APPLICATION AND WARNING INFORMATION
SECTION 17

- Upgraded for use with Grades 70, 80 and 100 Chain.
- Utilizes standard Crosby A-323 Alloy Eye Grab Hooks.
- New design one piece forged handle.
- Continuous take-up feature provides finite adjustment to tie down load.
- One piece assembly, no bolts or nuts to loosen.
- Ratchet spring is rust proofed.
- All load bearing or holding parts forged.
- Easy operating positive ratchet.
- Binders shown with Proof Loads have been individually proof tested to values shown, prior to shipment.
- Meets or exceeds requirements of US DOT FMCSA Part 393 Subpart I.
- Matches the Working Load Limit of Grade 100 chain except for 5/8" size.

Crosby LEBUS L-140 Standard Ratchet Type Load Binders

Model	Stock No.	Min-Max Chain Size (in)	Working Load Limit (lb)	Proof Load (lb)	Weight Each (lb)	Handle Length (in)	Barrel Length (in)	Take Up (in)	Dimensions (in)							
									A	B	C	E	E1	F	F1	G
R-7	1048404	5/16-3/8	8800	17600	12.11	14	10	8.0	14.00	1.38	2.75	22.94	30.94	25.13	33.13	.50
R-A	1048422	3/8-1/2	15000	30000	14.70	14	10	8.0	14.00	1.38	2.75	25.25	33.25	27.63	35.63	.63
R-C	1048440	1/2-5/8	16000	32000	14.55	14	10	8.0	14.00	1.38	2.75	26.38	34.38	29.44	37.44	.72

3:1 Design Factor.

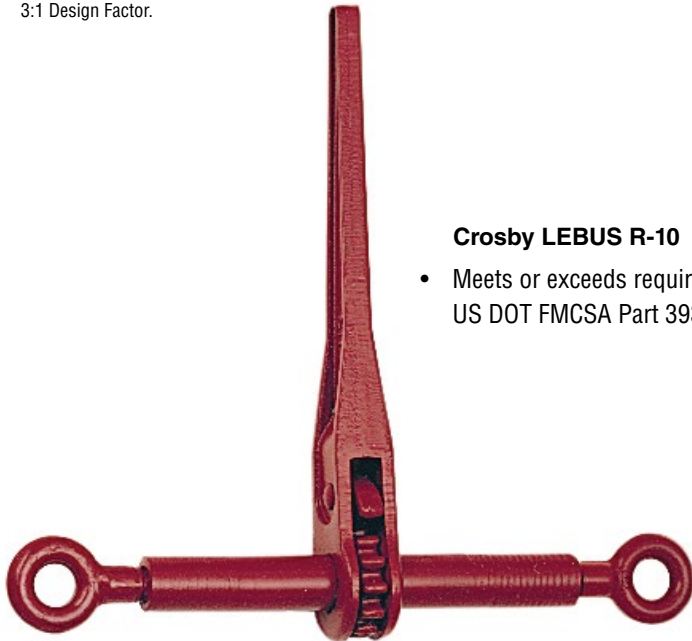

Crosby LEBUS R-10

- Meets or exceeds requirements of US DOT FMCSA Part 393 Subpart I.

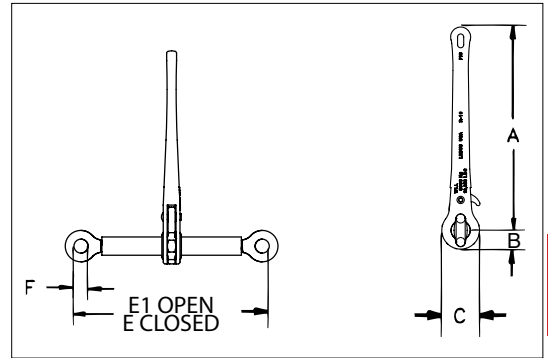

13

Crosby LEBUS R-10 Binder without Links and Hooks

Model	Stock No.	Working Load Limit (lb)	Weight Each (lb)	Handle Length (in)	Barrel Length (in)	Take Up (in)	Dimensions (in)					
							A	B	C	E	E1	F
R-10	1048468	16000	8.04	14	10	8.0	14	1.38	2.75	14	22	1.00

3:1 Design Factor.