

IPH10E

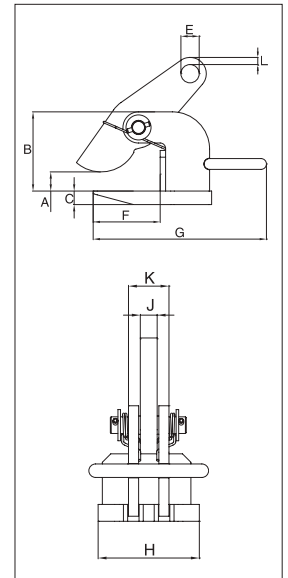

For horizontal lifting and transfer

- Available in capacities of 2.0 thru 25 metric tons.
- Wide variety of jaw openings available: 0 to 4.75".
- Welded alloy steel body for strength and smaller size. Forged alloy, components where required.
- Equipped with handle for easy placement.
- Individually Proof Tested to 2 times the Working Load Limit with certification.
- Company name (CrosbyIP), logo, Working Load Limit and jaw opening permanently stamped on body.
- Each product is individually serialized, with the serial number and Proof Load test date stamped on body. User manual with test certificate is included with each clamp.
- Maintenance and repair spare kits are available.



Model IPH10E

Load Rated

Model	Working Load Limit (Per Pair) (t)*	Stock No.	Weight Each (lb)	Dimensions (in)									
				Jaw A	B	C	E	F	G	H	J	K	L
IPH10E	2	2703542	24.0	0 - 2.38	4.61	0.63	0.87	4.29	10.08	4.33	0.79	1.57	0.35
IPH10E	3	2703543	32.0	0 - 2.38	4.61	0.79	1.02	4.29	10.47	4.72	0.79	1.89	0.43
IPH10E	4.5	2703544	46.0	0 - 2.38	5.20	0.98	1.18	4.09	11.02	5.12	0.79	1.89	0.47
IPH10E	6	2703545	56.0	0 - 2.38	5.63	0.98	1.42	4.84	12.60	5.12	0.79	1.89	0.55
IPH10E	9	2703546	80.0	0 - 2.38	6.18	1.18	1.69	5.24	12.99	5.51	0.98	2.44	0.63
IPH10E	12	2703547	94.0	0 - 2.38	6.77	1.18	1.85	5.55	13.90	5.91	0.98	2.44	0.67

* Design Factor based on EN 13155 and ASME B30.20.

Model IPH10JE

Model	Working Load Limit (Per Pair) (t)*	Stock No.	Weight Each (lb)	Dimensions (in)									
				Jaw A	B	C	E	F	G	H	J	K	L
IPH10JE	3	2703553	19.0	2.38 - 4.75	6.97	0.79	1.02	4.29	10.47	4.72	0.79	1.89	0.43
IPH10JE	4.5	2703554	26.0	2.38 - 4.75	7.56	0.98	1.18	4.09	11.02	5.12	0.79	1.89	0.47
IPH10JE	6	2703555	33.0	2.38 - 4.75	7.99	0.98	1.42	4.84	12.60	5.12	0.79	1.89	0.55
IPH10JE	9	2703556	45.0	2.38 - 4.75	8.54	1.18	1.18	5.24	12.99	5.51	0.98	2.44	0.63
IPH10JE	12	2703557	53.0	2.38 - 4.75	9.13	1.18	1.85	5.55	13.90	5.91	0.98	2.44	0.67

* Design Factor based on EN 13155 and ASME B30.20.

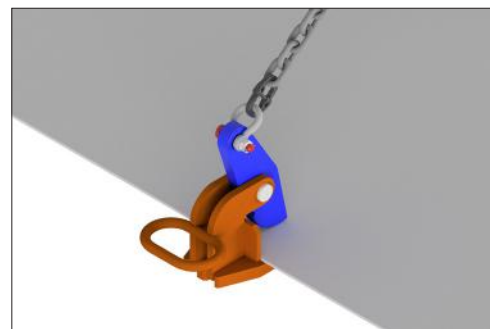
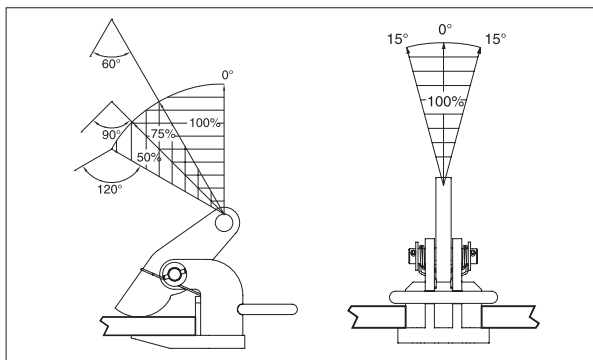

12